



023-12157

10' to 20' Belmont Safety Hatch System with Front Mount Brackets

FEATURES :

- System mounts directly to ladder for stability
- Ground level operation to open, close and secure hatch
- Safe transitions with built-in extension pole
- Manually operated drive unit with simple crank
- Installs on systems from 10' to 20'
- For use on hatches from 30" square to 36" square
- Assembly required, padlock not included
- Includes all required components and fasteners:
 - (6) Brackets for front mounted installation on flat bar stock up to 1/2" thick and 4" deep (shims included for adjustability)
 - (1) Lifting tube extension
 - (2) Intermediate guide brackets
 - (1) Drill bit rivet adapter

ITEM WEIGHT :

- 43.6 lbs. (19.8 kg)

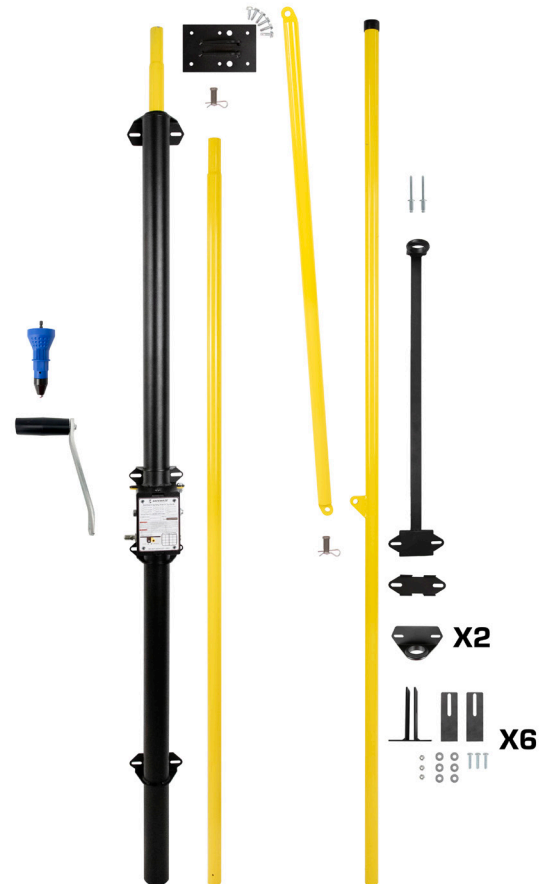

USER WEIGHT CAPACITY	
ANSI	N/A
OSHA	N/A

STANDARD COMPLIANT WITH	
ANSI	N/A
OSHA	N/A

RELATED PRODUCTS	
023-12158	20' to 27' Belmont Safety Hatch System with Front Mount Brackets
023-12159	27' to 34' Belmont Safety Hatch System with Front Mount Brackets
023-12164	Front Mount Backing Plate Set, Belmont Safety Hatch

COMPONENT	MATERIAL SPECIFICATION
System	Powder coated steel
Fasteners	Zinc plated steel



023-12158

20' to 27' Belmont Safety Hatch System with Front Mount Brackets

FEATURES :

- System mounts directly to ladder for stability
- Ground level operation to open, close and secure hatch
- Safe transitions with built-in extension pole
- Manually operated drive unit with simple crank
- Installs on systems from 20' to 27'
- For use on hatches from 30" square to 36" square
- Assembly required, padlock not included
- Includes all required components and fasteners:
 - (8) Brackets for front mounted installation on flat bar stock up to 1/2" thick and 4" deep (shims included for adjustability)
 - (2) Lifting tube extensions
 - (4) Intermediate guide brackets
 - (1) Drill bit rivet adapter

ITEM WEIGHT :

- 50.8 lbs. (23.0 kg)

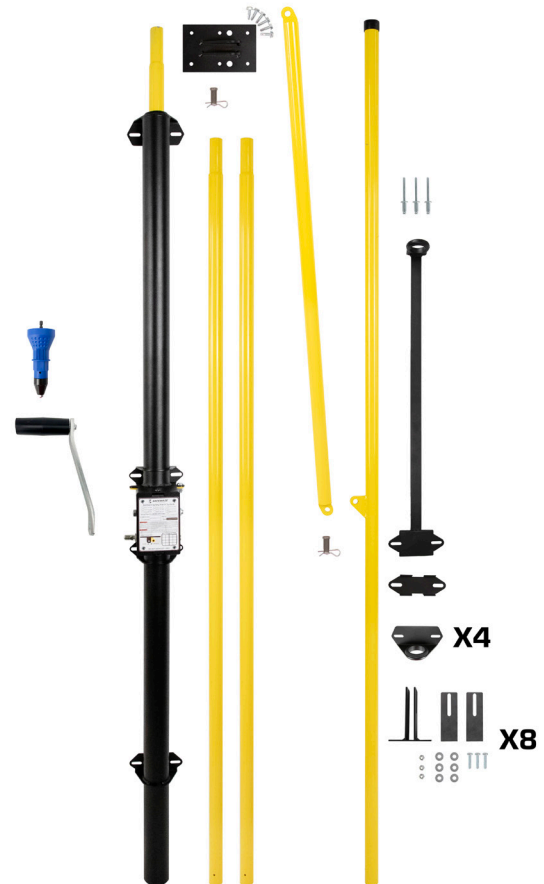

USER WEIGHT CAPACITY	
ANSI	N/A
OSHA	N/A

STANDARD COMPLIANT WITH	
ANSI	N/A
OSHA	N/A

RELATED PRODUCTS	
023-12157	10' to 20' Belmont Safety Hatch System with Front Mount Brackets
023-12159	27' to 34' Belmont Safety Hatch System with Front Mount Brackets
023-12164	Front Mount Backing Plate Set, Belmont Safety Hatch

COMPONENT	MATERIAL SPECIFICATION
System	Powder coated steel
Fasteners	Zinc plated steel



023-12159

27' to 34' Belmont Safety Hatch System with Front Mount Brackets

FEATURES :

- System mounts directly to ladder for stability
- Ground level operation to open, close and secure hatch
- Safe transitions with built-in extension pole
- Manually operated drive unit with simple crank
- Installs on systems from 27' to 34'
- For use on hatches from 30" square to 36" square
- Assembly required, padlock not included
- Includes all required components and fasteners:
 - (10) Brackets for front mounted installation on flat bar stock up to 1/2" thick and 4" deep (shims included for adjustability)
 - (3) Lifting tube extensions
 - (6) Intermediate guide brackets
 - (1) Drill bit rivet adapter

ITEM WEIGHT :

- 57.9 lbs. (26.3 kg)



USER WEIGHT CAPACITY	
ANSI	N/A
OSHA	N/A

STANDARD COMPLIANT WITH	
ANSI	N/A
OSHA	N/A

RELATED PRODUCTS	
023-12157	10' to 20' Belmont Safety Hatch System with Front Mount Brackets
023-12158	20' to 27' Belmont Safety Hatch System with Front Mount Brackets
023-12164	Front Mount Backing Plate Set, Belmont Safety Hatch

COMPONENT	MATERIAL SPECIFICATION
System	Powder coated steel
Fasteners	Zinc plated steel