

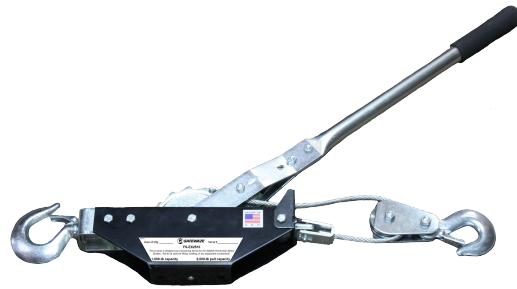

SAFEWAZE

FS-EX2510 USER INSTRUCTION MANUAL



WARNING

This product is part of a personal fall arrest, work positioning, or rescue system. The manufacturer's instructions must be provided to users of this equipment. The user must follow the manufacturer's instructions for each component of the system. The user must read and understand these instructions before using this equipment. Manufacturer's instructions must be followed for proper use and maintenance of this equipment. Alterations to this product, misuse of this product, or failure to follow instructions may result in serious injury or death.



IMPORTANT

Questions regarding the use, care, or suitability of this equipment for your application? Contact Safewaze.



IMPORTANT

Record identification information before using this product. Identification information may be found on the equipment label. Annual inspections by a Competent Person other than the user must be recorded in the Inspection Log on (Page 6) of this manual.

Table of Contents

Safety.....	2	Installation and Tensioning.....	4-5
Specifications.....	2	Tensioning and Releasing Tension.....	5
Inspection.....	2-3	Examples of Wire Rope Damage.....	6
Fall Protection and Rescue Plan.....	3	Labeling.....	6
Setup.....	3	Inspection Log.....	6
Operation.....	4		

SAFETY INFORMATION AND PRECAUTIONS

User must read, understand, and follow all safety and usage information contained within this manual prior to use of this equipment. Failure to follow all safety and usage information can result in serious injury or death.

Intended Use:

The equipment covered in this manual is intended for use as part of a complete Personal Fall Arrest System (PFAS).

Use of this equipment for any other purpose, such as material handling, sports activities, or other action not described in these User Instructions is not approved by Safewaze. Use of this equipment in a manner outside the scope of those covered within this Manual can result in serious injury or death.

The equipment covered in this manual is only to be used by trained personnel in workplace applications.

1. **Do not** use this equipment for any purpose other than tensioning the SafeLink Horizontal Lifeline System.
2. **Do not operate if the FS-EX2510 is restricted from forming a straight line with HLL direction.**
3. **Do not operate the FS-EX2510 with twisted, kinked, or damaged wire rope.** Inspect wire rope carefully before every use.
4. **Do not use the FS-EX2510 if inspection reveals damage or malfunction.** Inspect the FS-EX2510 carefully and test operation prior to each use.
5. Do not attempt to add or use any type of "extension" to the FS-EX2510 Handle.
6. Do not operate with wire rope not centered in its groove.
7. Do not remove or cover warning labels and/or tags.
8. The warnings, precautions, and instructions discussed in this instruction manual cannot cover all possible conditions and situations that may occur.

SPECIFICATIONS

Working Load: 1,000 lb. capacity

Pull Capacity: 2,000 lb. pull capacity

Maximum Length: 12 ft.

INSPECTION

This equipment must be inspected prior to each use, and at least annually by a Competent Person other than the user. If inspection reveals any damage such as, but not limited to: kinked or frayed cable, handle bent or deformed, anchor and/or load hook damaged or inoperable, cut or damaged cable strands, frame damage such as bending or twisting, pawl spring damage, or pawl spring nonoperational, or missing.

Not only must the FS-ES2510 be inspected prior to each use, it must also be inspected as an overall component of the SafeLink Horizontal Lifeline System. Please see SafeLink Horizontal Lifeline System Manual for specific inspection criteria.

1. Check operating components and controls for proper operation, and proper adjustment.
2. Braking System Inspection
 - a. The braking system must automatically stop and hold up to the rated load if the lever is released.
3. Hook Inspection

Check hooks for the following:

 - a. distortion, such as bending, twisting, or increased throat opening
 - b. wear
 - c. cracks, nicks, or gouges
 - d. hook attachment and securing means

4. Wire Rope Inspection

Wire rope should be visually inspected by the user or other designated person prior to each use. These visual observations should be concerned with discovering gross damage, such as listed below, which may be an immediate hazard:

- a. distortion of the rope such as kinking, crushing, unstranding, birdcaging, main strand displacement, or core protrusion
- b. general corrosion
- c. broken or cut strands
- d. number, distribution, and type of visible broken wires:
 - 1) 12 randomly distributed broken wires in one lay or four broken wires in one strand in one lay
 - 2) one outer wire broken at the contact point with the core of the rope which has worked its way out of the rope structure and protrudes or loops out from the rope structure.

If inspection reveals any damage that may affect proper performance and operation of the FS-EX2510, it must be removed from service and repaired or replaced.

FALL PROTECTION & RESCUE PLAN

When using this equipment employers must create and maintain a Fall Protection and Rescue Plan, and provide the means to implement those plans. The plans must be communicated to equipment users, authorized persons, and rescuers. These plans must meet ANSI Z359.2 "Minimum Requirements for a Comprehensive Managed Fall Protection Program." They should include the requirements and guidelines for the employer's managed Fall Protection Program. This would include eliminating and controlling fall hazards, duties and training, policies, fall protection procedures, rescue procedures, incident investigations, and evaluation of the program's effectiveness.

SETUP

The structure to which the FS-EX2510 is attached must be capable of withstanding forces generated in the event of a fall and must meet specifications for fall protection anchorages as defined by OSHA.

The FS-EX2510 is intended for use as a **component** of our Safewaze Mobile SafeLink System. The Mobile SafeLink System, when used in conjunction with the FS-EX2510, is a Personal Fall Arrest System (PFAS). The FS-EX2510 **must never** be used as a stand alone piece or single point anchorage for Fall Protection

Should the FS-EX2510 be used for any purpose other than those specified in this manual, it must be removed from service as part of the SafeLink System.

The user must ensure that the FS-EX2510 Load and Anchor Hook are properly and fully connected to the anchorage point, and the SafeLink System. Figures 1 and 2 illustrate examples of correct, and incorrect attachment.

Figure 1: Correct FS-EX2510 Hook Attachment

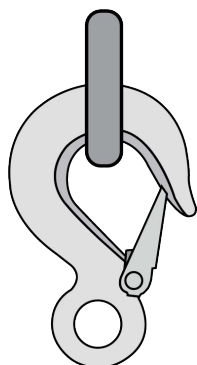

Figure 2: Incorrect FS-EX2510 Hook Attachment



OPERATION

TO PREVENT SERIOUS INJURY: Operation of the FS-EX2510 involves more than pulling the lever. The use of the FS-EX2510 Come-A-Long is subject to certain hazards that are specific to this type of equipment. The user should be familiar with the controls and function of this equipment and any hazards related to such use.

Do not use the FS-EX2510 for vertical lifting.

BEFORE USE

User must have read and understood this manual and be familiar with safe operation of this equipment. Failure to follow these instructions in the use of this equipment may result in serious injury or death.

Care should be taken in choosing a location for installation. The desired location should be free of hazards such as electrical hazards, moving equipment, extreme temperatures, or any hazard that may interfere in the proper function or operation of this equipment.

FS-EX2510 CONTROLS

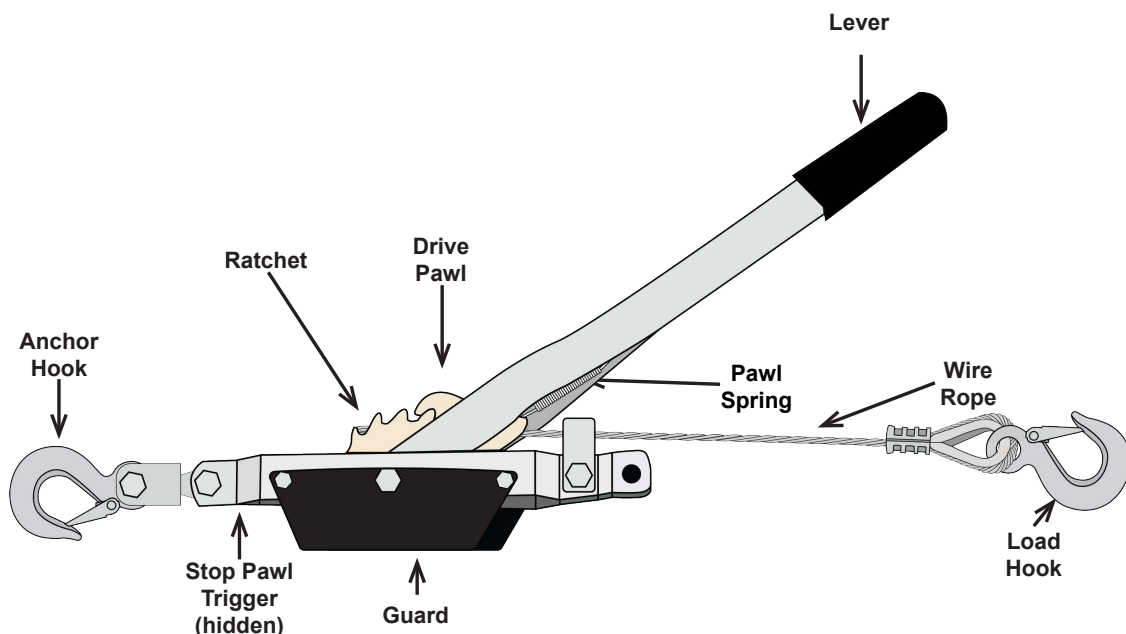

INSTALLATION AND TENSIONING

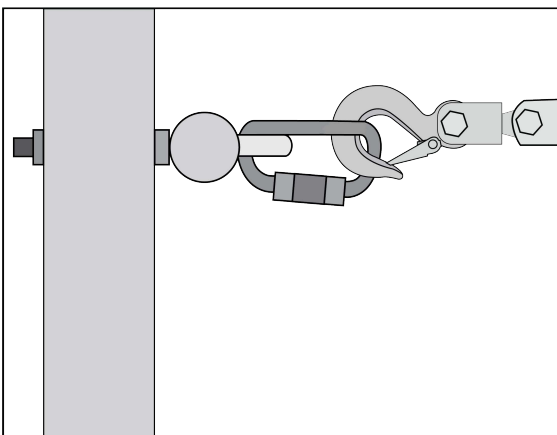

Step 1: Connect the Anchor Hook of the FS-EX2510 to a suitable anchorage.

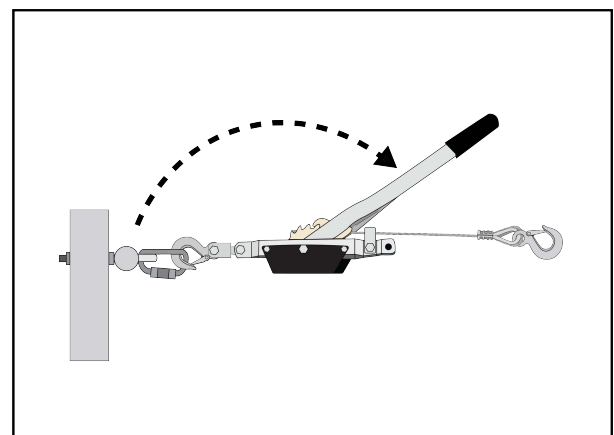

Step 2: Swing the handle away from the Anchor Hook end of the FS-EX2510 to expose the Drive Pawl.

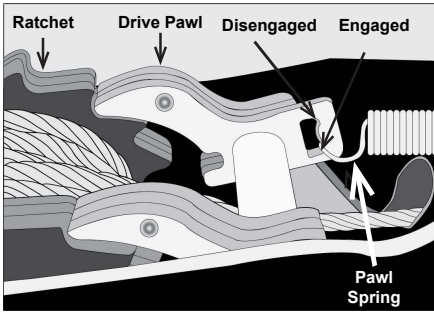

Step 3: Slide the Pawl Spring from the Engaged Position to the Disengaged Position. This will hold the Drive Pawl clear of the Ratchet.

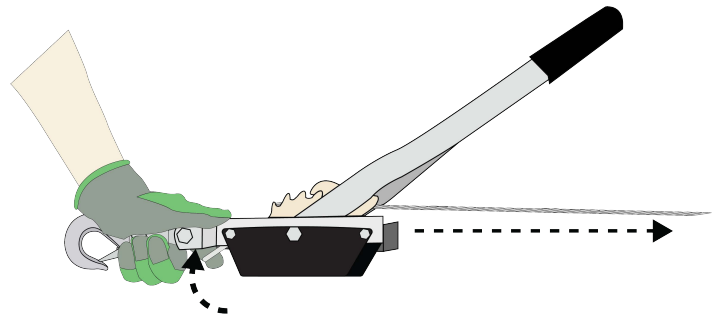

Step 4: Hold handle firmly towards the Load Hook end of the FS-EX2510. Depress the Stop Pawl Trigger and simultaneously pull desired amount of cable from the device.

TENSIONING AND RELEASING TENSION ON THE SYSTEM

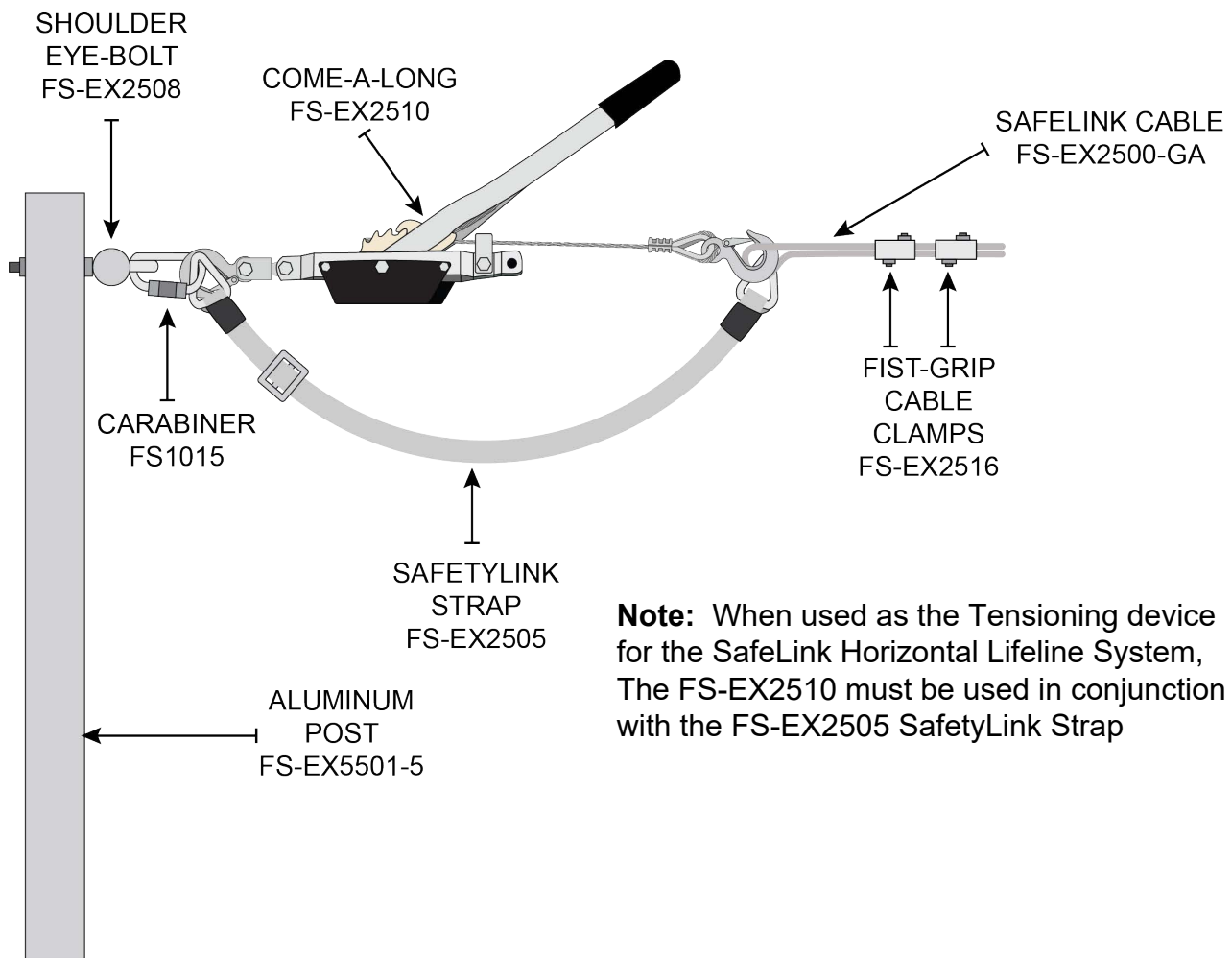

Note: When used as the Tensioning device for the SafeLink Horizontal Lifeline System, The FS-EX2510 must be used in conjunction with the FS-EX2505 SafetyLink Strap

Step 5: Slide the Pawl Spring from the Disengaged to Engaged Position once the FS-EX2510 is connected to the SafeLink Horizontal Lifeline System cable. Pull the handle in a back and forth motion to properly tension the SafeLink System. (See Safelink Instruction Manual for specific instructions)

Step 6: To release tension, Slide the Pawl Spring to the Disengaged Position. Steadily push the handle until the Drive Pawl pushes and disengages the Stop Pawl to clear the ratchet teeth. This releases the load one notch. Repeat this handle motion as necessary to release desired tension.

EXAMPLES OF WIRE ROPE DAMAGE



Bird-Caging

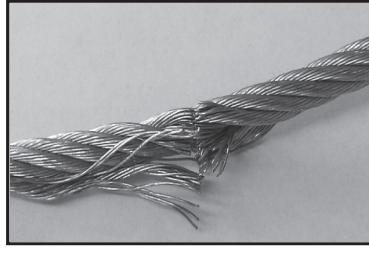

Broken Wires

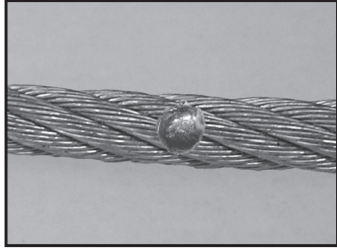

Welding Spatter



Kinked Wire Rope

LABELING

020161	SAFEWAZE	Serial # _____
Date of Mfg: _____		
FS-EX2510		
This product is designed as a tensioning device for the Safelink Horizontal Lifeline System. Not to be used for lifting, hoisting, of any equipment or personnel.		
1,000-lb capacity		2,000-lb pull capacity

INSPECTION LOG

Date	Inspection Items Noted	Corrective Action	Initials

Safewaze

225 Wilshire Ave SW Concord, NC 28025

PHONE: 1-800-230-0319 FAX: 1-704-262-9051

WEB: safewaze.com EMAIL: info@safewaze.com