

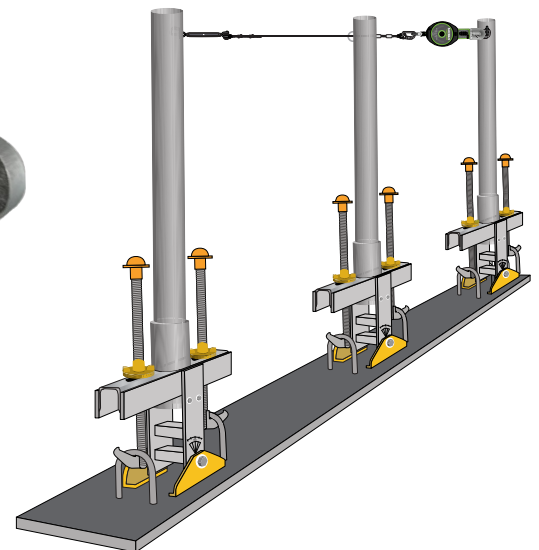

SafeLink Loop Rebar Base

Part of a complete solution for mounting Horizontal Lifeline Systems.

- **Convenient:** Requires no special tools to install
- **Versatile:** Adjustable base mounts to most sizes of pre-stressed concrete beams with rebar loops



SafeLink Loop Rebar Base

— 019-8051

FEATURES

- Lightweight aluminum construction
- For use on loop rebar as part of an HLL system
- Adjustable base for angled surfaces
- Rebar safety caps
- Qualified person required for installation
- Capacity 310 lbs. (141kg) per user
- Meets OSHA 1910.66, OSHA 1926.502

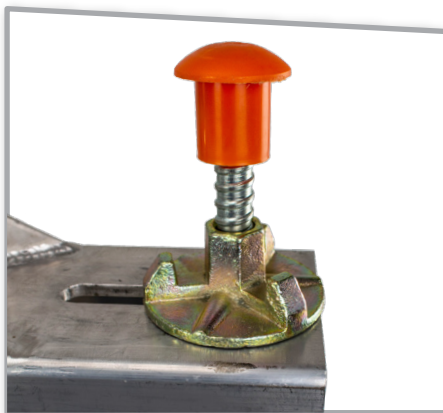

Rebar safety caps

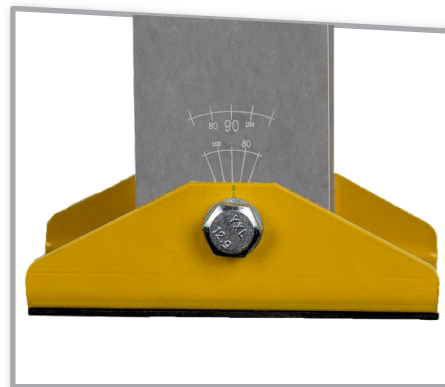

Base is marked with allowable range for angled surfaces

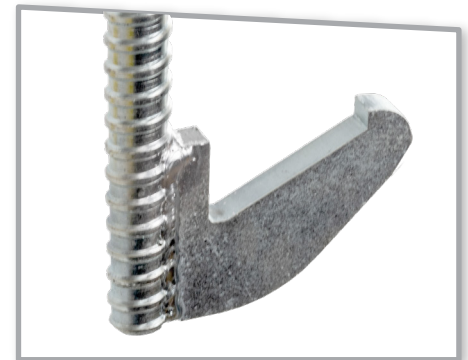

Rebar loop hook with adjustable thread bars

RELATED PRODUCTS

65' SafeLink: Come-A-Long Kit

— FS-EX10000

65' SafeLink: Turnbuckle Kit

— FS-EX10500

The SafeLink Loop Rebar Base is designed for use with SafeLink HLLs and can be used with any HLL.

SafeLink Anchor Post

— FS-EX5501-5

Placed at each end of the Mobile SafeLink Horizontal Lifeline System, elevating the cable for overhead attachment.

